



TREKHAKEN • ATTELAGES • ANHÄNGERVORRICHTUNGEN • TOWBARS • ENHANCES • ANHÆNGERTRÆK

Montagehandleiding | instructions de montage | Einbauanleitung | Mounting instruction
Instrucciones de montaje | monteringsvejledning



Nissan Leaf (type ZE0) 11/'10 -

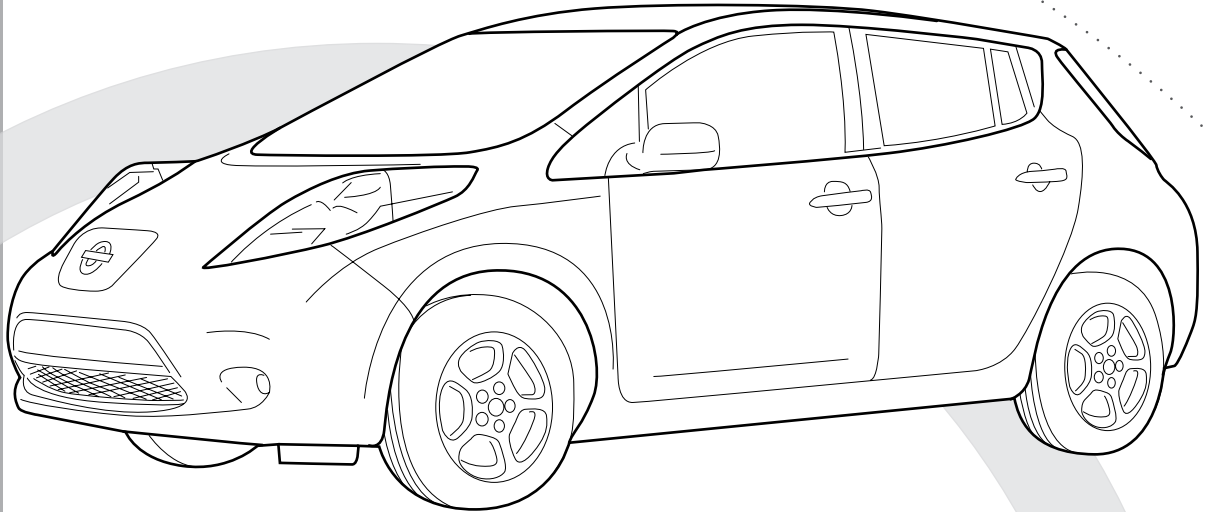

Nissan Leaf (type ZE1) 08/'17 -

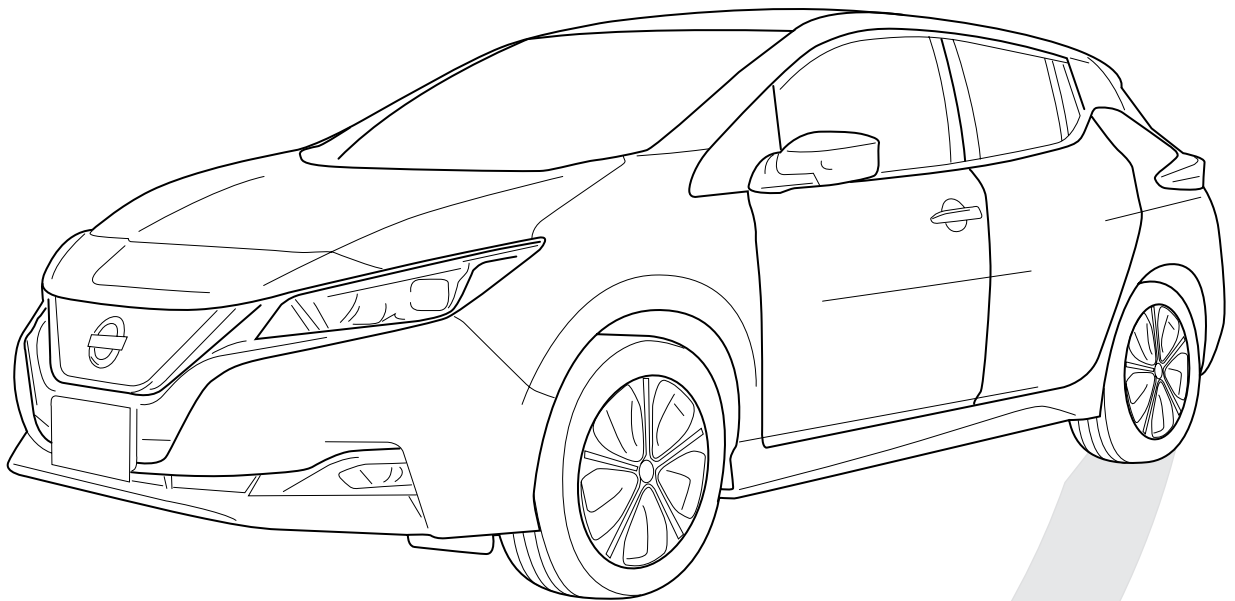

NO TOWING

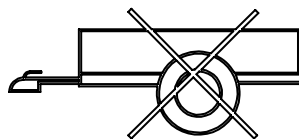

Montage

- Voor aanvang van de montage dient de constructie gecontroleerd te worden op transport schade.
- Raadpleeg aandachtig de montagehandleiding. Alle instructies dienen gevolgd te worden.
- Voor de montage moet de constructie eerst op het voertuig gepresenteerd worden.
- Bij het boren van gaten, controleren dat aanwezige bekabelingen niet beschadigd kunnen worden. Verwijder antidreun of bitumenlaag. Geboorde gaten en carrosserie onderdelen met corrosiewerende verf behandelen.
- Als het voertuig geen standaard bumpers heeft (speciale serie, sportuitvoeringen, Tuning parts ...), dient de uitsparingsmal gecontroleerd te worden. Neem bij twijfel contact op met GDW.

De geleverde constructie is enkel gemonteerd voor stockering, daarom moeten alle onderdelen worden gedemonteerd!

Garantie

- Na 1.000 km gebruik en ten minste 1 keer per jaar hoeft de constructie gecontroleerd te worden:
 - * Alle boutverbindingen controleren en bij spannen als nodig.
 - * Beschadiging aan de verf herstellen.
 - * Als de constructie door een externe belasting geraakt wordt moet deze vervangen worden.
 - * De interne delen van het afneembaar systeem moeten ingevet worden.

Gebruik

- Indien de kogelstang de kentekenplaat of het mistlicht geheel of gedeeltelijk bedekt MOET deze bij niet gebruik verwijderd worden.

De belasting van een aanhangwagen en van een accessoire dat op de koppelingskogel wordt voorzien, zijn anders van aard. Voor beiden kunnen verschillende limieten van toepassing zijn. Hiervoor verwijzen we naar het instructieboekje van de wagen of naar uw concessiehouder.

Montage

- S'assurer que la construction n'ait pas été endommagé durant le transport. Vérifier la référence.
- Consulter attentivement la notice de pose et suivre à la lettre les instructions de montage de la construction.
- Présenter la construction sous le véhicule avant d'effectuer le montage.
- Si des forages sont nécessaires, s'assurer de l'absence de câbles électriques, de freinage ou autres. Enlever la couche d'antitremblement ou couche de bétume et traiter les tôles ou tubes forés avec un produit anti-corrosif.
- Si le véhicule est équipé de pare-chocs non standards (séries spéciales, kits sport, tuning ...), il est impératif de consulter le service technique de GDW avant de procéder au montage.

La construction livré est uniquement monté pour stockage, il faut démonter les parties!

Garantie

- La construction doit être contrôlé après les 1.000 premiers km d'utilisation et ensuite au moins une fois par an:
 - * Contrôler toute la visserie et resserrer si nécessaire
 - * Réparer les dommages qu'aurait subi la peinture
 - * Remplacer les pièces qui auraient été endommagées suite à un accident ou une collision
 - * Graisser les parties intérieures des systèmes escamotables

Utilisation

- Si la rotule ou la boule est positionnée devant la plaque d'immatriculation ou le feu anti-brouillard, il est OBLIGATOIRE de la retirer quand elle n'est pas utilisée !

La charge d'une remorque ou d'un accessoire prévue sur la boule d'attelage, est de nature diverse. Pour ces deux éléments, il peut y avoir des limites d'utilisation. Nous vous recommandons de vous référer à votre livret d'instructions ou de vous renseigner chez votre concessionnaire.

Fitting

- Make sure that the construction has not been damaged during transport and it is the right reference for the vehicle.
- Read the fitting instruction before starting and follow them very precisely during the fitting.
- Present the construction under the car first to check if all points are right.
- If holes have to be drilled, check that no wires can be damaged, remove all soundproofing material, clean and protect the drilled holes with an anticorrosive product.
- If the vehicle is equipped with special bumpers (sport or tuning parts...) first contact the technical service of GDW to be sure that the construction can be fitted.

The construction delivered is only for storage, the parts have to be disassembled!

Guarantee

- The construction has to be checked after 1.000 km and every year:
 - * All bolts should be checked and retightened if necessary
 - * Repair any damage to the paint finish
 - * Replace any damaged components
 - * Parts of the detachable systems must be kept well greased.

Use

- If the mounted ball covers the number plate or the fog light, it must always be removed when not in use.

The load of a trailer and of an accessory fitted on the towing ball are of a different nature. Different limits may apply to both. For this matter, we refer to the instruction manual of the vehicle or we advise you to contact your concessionaire.

Montage

- Vor Anfang der Montage muss die Konstruktion auf Transportschäden kontrolliert werden.
- Aufmerksam die Anbauanleitung zu Rate ziehen. Alle Anweisungen sollen befolgt werden.
- Erst die Konstruktion und das Fahrzeug kontrollieren, danach montieren.
- Vor dem Bohren der Löcher prüfen dass anwesende Kabel nicht beschädigt werden können. Den Antidröhschutz und Unterbodenschutz entfernen. Gebohrte Löcher und Karosserieunterteile mit einer korrosionsfesten Farbe behandeln.
- Falls das Fahrzeug keine Standardstoßstangen hat (spezielle Serie, Sportausführungen, Tuning ...), muss Aussparung nachprüfen. Im Zweifelsfall, GDW kontaktieren.

Die gelieferte Konstruktion ist für die Lagerung montiert, bitte die Unterteile abmontieren!

Garantie

- Nach 1.000 Km Gebrauch und wenigstens 1 Mal pro Jahr muss die Konstruktion nachgeprüft werden:
 - * Alle Bolzenverbindungen nachprüfen und nachziehen falls nötig.
 - * Beschädigungen an der Farbe ausbessern.
 - * Falls die Konstruktion durch eine extreme Belastung beschädigt wurde muss diese ersetzt werden.
 - * Die innere Teile vom abnehmbaren System einfetten.

Gebrauch

- Falls die Kugel das Kennzeichen oder den Nebelscheinwerfer ganz oder zum Teil verdeckt, muss diese bei Nichtgebrauch, entfernt werden.

Die Belastung eines Anhängers und eines Zubehörs, die man auf einer Kupplungskugel voraussetzt, ist wesentlich anders. Für beide gilt, dass diese unterschiedlich begrenzt sein können. Deswegen möchten wir verweisen auf die Bedienungsanleitung des Fahrzeugs oder auf Ihren Vertragshändler.

Montaje

- Asegurarse de que la construcción no ha sido dañado durante el transporte. Verificar la referencia. Leer las instrucciones de montaje y seguir los pasos que se indican.
- Presentar la construcción debajo del vehículo antes de realizar el montaje.
- Si es necesario hacer orificios asegurarse de que no hay cables eléctricos, de frenado u otros.
- Las piezas que se tienen que taladrar hay que tratarlas con un producto anticorrosión.
- Si el vehículo está equipado de un para golpes que no es de serie (especiales, kits sport, tuning...), informarse antes de montar la construcción ya que puede no servir si el paragolpes no es estándar.

Antes iniciar el montaje de la construcción separar las piezas que lo componen!

Garantía

- La construcción debe revisarse después de los 1000 kilómetros de utilización y después una vez al año:
 - * Revisar toda la tortillería y apretarla si fuera necesario
 - * Reparar la pintura dañada
 - * Reemplazar piezas en caso de colisión
 - * Engrasar las partes interiores del enganche extraíble

Utilización

- Si la bola tapa la matrícula o la luz antiniebla, es OBLIGATORIO quitar la bola cuando no se utiliza!

Montering

- Før montering skal sammensætningen kontrolleres for evt. transportskader og at det passer til den pågældende bil.
- Læs monteringsvejledningen før start og følg alle anvisninger under monteringen.
- Hvis det er nødvendigt at bore og/eller skære i bilens metaldele, sørg for at ingen ledninger er i vejen. Snitfladerne skal behandles med et rusthæmmende middel, og metalspånere skal fjernes.
- Hvis bilen er udstyret med speciel kofanger (speciel serie, sportsudstyr og lign.), så kontakt først Dansk GDW for at sikre, at sammensætningen kan monteres.
- Påse at der ikke kommer voks, støjdempningsmateriale, olie eller lign. på bolte og møtrikker. Dette giver en dårlig friktion i gevindet, hvilket kan resultere i løsdrejning af boltene.

Garanti

- Alle bolte skal efterspændes efter ca. 1.000 km's brug.
- Det er ikke tilladt at lave konstruktionsændringer på sammensætningen. Eksempler på konstruktionsændringer er svejsning og boring.
- Har et sammensætningen været udsat for ydre påvirkninger, f.eks. en trafikulykke eller anden form for påkørsel, er det ikke længere sikkert og bør straks udskiftes.
- Den anførte maksimale belastning/D-værdi samt kugletrykket må ikke overskrides.
- Trækkes vil som regel have en større maksimal belastning/D-værdi og maksimalt kugletryk end bilen. Ved brug af trækkes skal man derfor være opmærksom på, hvilken koblingsvægt og maksimal kugletryk, som er angivet i bilens papirer.
 - * Kuglen skal altid være rengjort og indsmurt i fedt. Hvis man anvender en kuglekobling med slingrestabilisator, følges dog anvisningerne fra fabrikanten af slingrestabilisatoren.
 - * Kuglediameteren skal regelmæssigt måles. Den må ikke være under 49 mm.
 - * Dansk GDW A/S kan ikke gøres ansvarlig for ukorrekt montage eller ukorrekt brug af sammensætningen.
 - * Hvis sammensætningen dækker nummerplade eller tågelygte, skal kuglen altid være afmonteret, når den ikke er i brug.

Belastningen af en trailer og af tilbehør tilkoblet anhængertræk er forskellige. Der kan være forskellige begrænsninger på begge. I disse tilfælde henviser vi til bilens manual, eller anbefaler dig at kontakte bilforhandleren

Montaggio

- Assicurarsi che il dispositivo di traino non si sia danneggiato durante il trasporto ed il codice sia quello giusto per il veicolo.
- Leggere le istruzioni di montaggio prima di iniziare l'installazione e seguirle con estrema precisione durante tutto il montaggio.
- In primo luogo, presentare la struttura sotto l'automobile per verificare che tutti i punti di attacco coincidano.
- Se si devono effettuare i fori, verificare che nessun cavo possa essere danneggiato, rimuovere tutti i materiali insonorizzanti, pulire e proteggere i fori effettuati con un prodotto anticorrosivo.
- Se il veicolo è dotato di paraurti speciali (sport o parti tuning ...), contattare il servizio tecnico di GDW assicurarsi che la barra di traino possa essere montata

Il dispositivo di traino così come imballato e consegnato è solo per l'immagazzinaggio, le parti devono essere smontate!

Garanzia

- Per conoscere la massa rimorchiabile della vostra auto, fare riferimento alla carta di circolazione o contattare il rivenditore. Le specifiche tecniche del carico di prova del dispositivo di traino non devono essere superate. Vedere la formula a pagina 5.
- La barra di traino deve essere controllata dopo 1.000 km ed ogni anno:
 - * Tutti i bulloni devono essere controllati e riserrati se necessario;
 - * Riparare eventuali danni alla finitura della vernice;
 - * Sostituire eventuali componenti danneggiati;
 - * Le parti del dispositivo di traino smontabili devono essere tenute ben lubrificate

Uso

- Se la sfera del dispositivo di traino copre la targa di immatricolazione o la luce antinebbia, deve essere sempre rimossa quando non viene utilizzato alcun rimorchio.

La massa rimorchiabile del veicolo potrebbe essere diversa dal valore riportato sul documento del gancio di traino. Per questo motivo, vi invitiamo a consultare sempre la carta di circolazione del veicolo (Pos. O.1) o a rivolgervi alla vostro concessionario di fiducia

Nissan Leaf 11/'10-

See the Certificate Of Conformity (COC) of your vehicle or contact your dealer to verify the max. trailer weight of your car!

MADE BY **gdw** **NO TOWING**  E6

EC APPROVAL N° **26R-030302**

BELGIUM

REF N° **2285T36** SERIE N° **D 0,00**

S 75

OMSCHRIJVING
Nissan Leaf 11/'10-

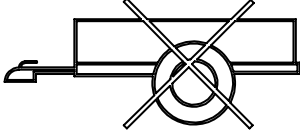
NO TOWING 

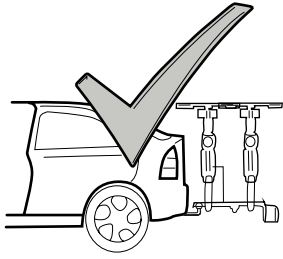



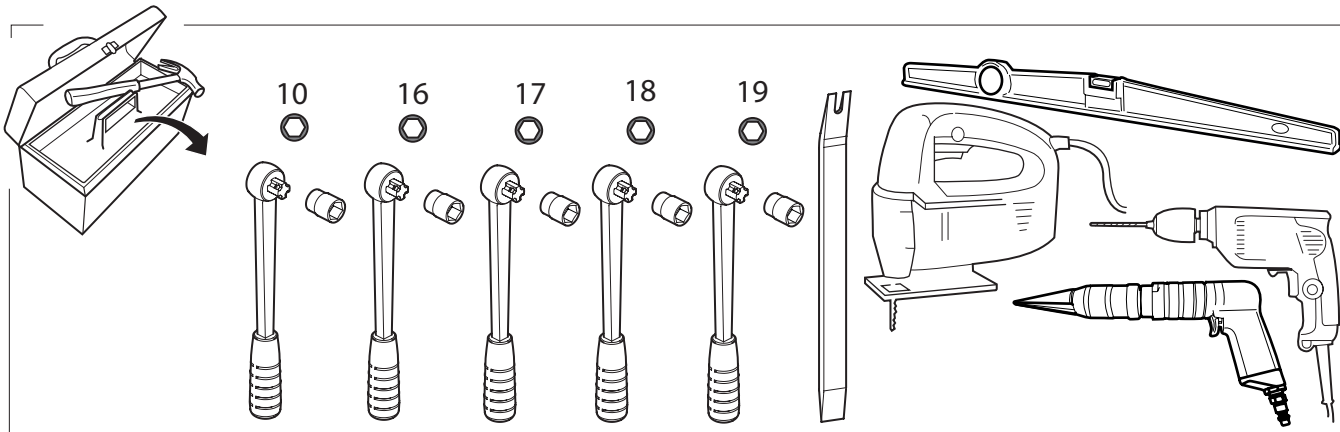



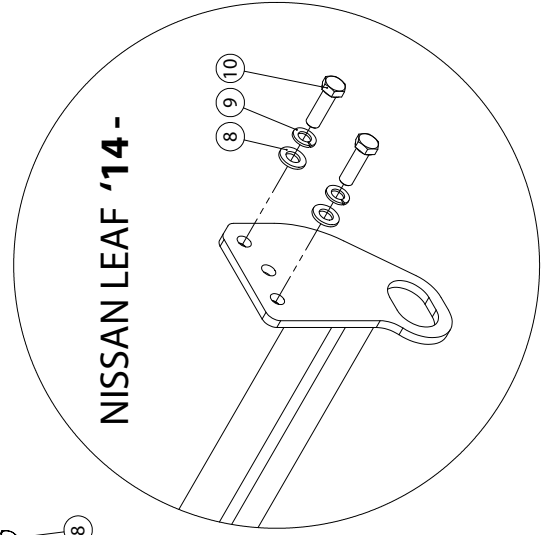
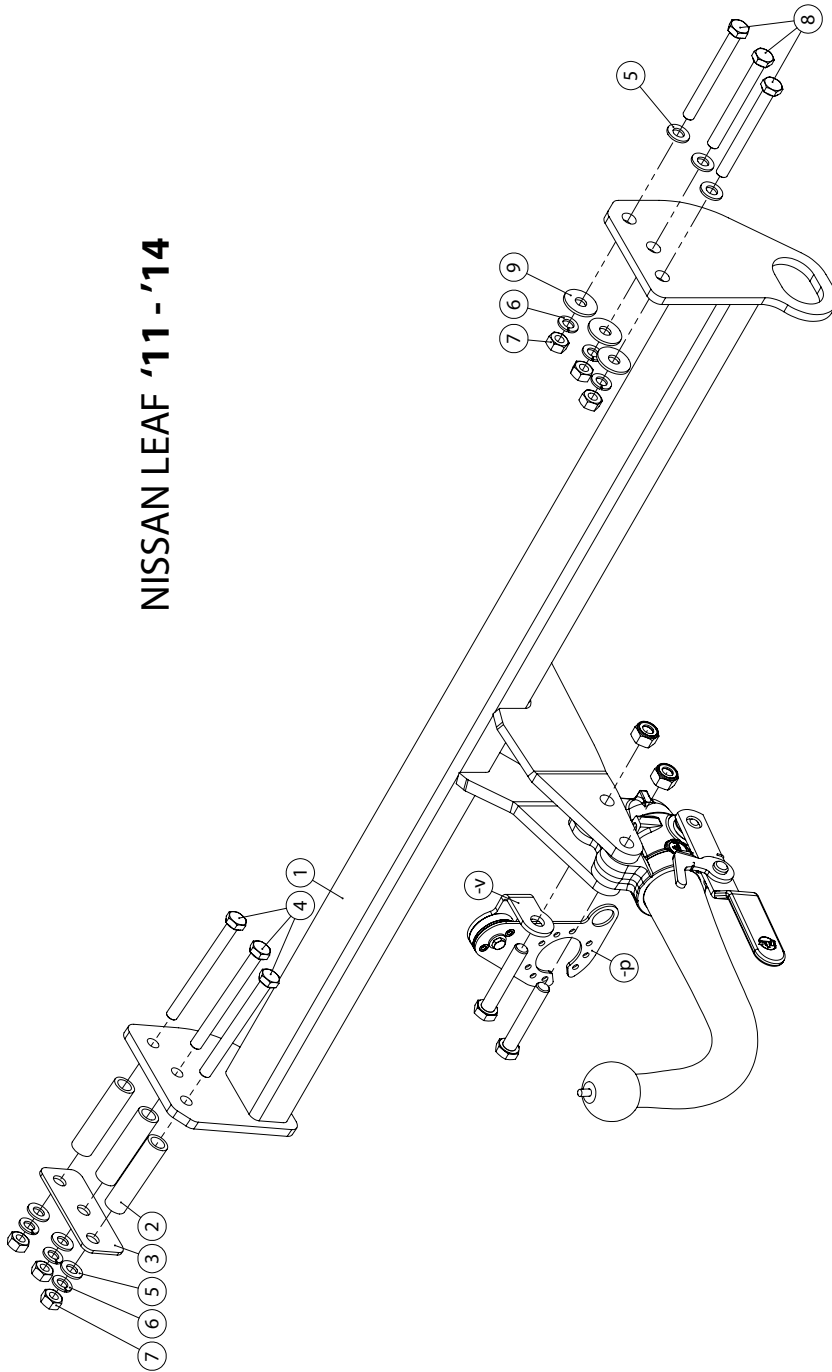

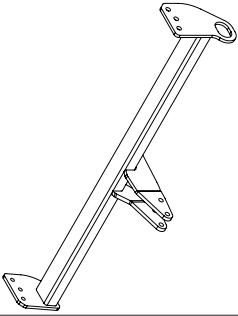
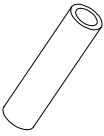
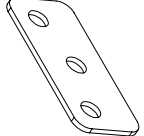
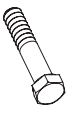





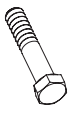

S =  = 75 kg

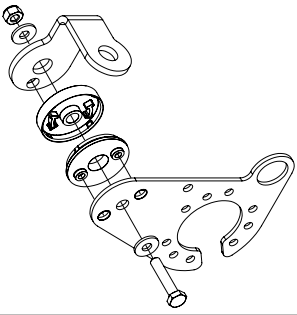



NISSAN LEAF '11 - '14

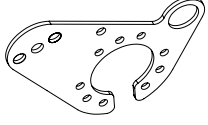

1		X1	GDW REF. 2285T36
2		X3	GDW REF. 2
3		X1	GDW REF. 3
4		X3	DIN931-M10X110_10.9
5		X6	DIN125-A10-140HV-ELVZ
6		X6	DIN128A-M10
7		X6	DIN934-M10_K110
8		X2	DIN125-A12-140HV-ELVZ
9		X2	DIN128A-M12
10		X2	DIN961-M12X1,25X40
11		X3	DIN931-M10X100_10.9
12		X3	DIN9021-M10-ELVZ

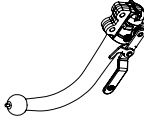
-P		X1	GDW REF. P39
↳		X1	GDW REF. 908.095
↳		X1	DIN985-M6
↳		X2	6,2 X 15,4 X 1,6 (NYLON)
↳		X1	GDW REF. 718.16.002
↳		X1	GDW REF. 718.16.003
↳		X1	GDW REF. 908.094
↳		X1	DIN933-M6 X 30

Geleverd met - Livré avec - Delivered with Gefiefert mit - Elementos adjuntos-Leveres med		
	X1	930.XL035T
	X2	DIN931-M12 X 70
	X2	DIN985-M12

1

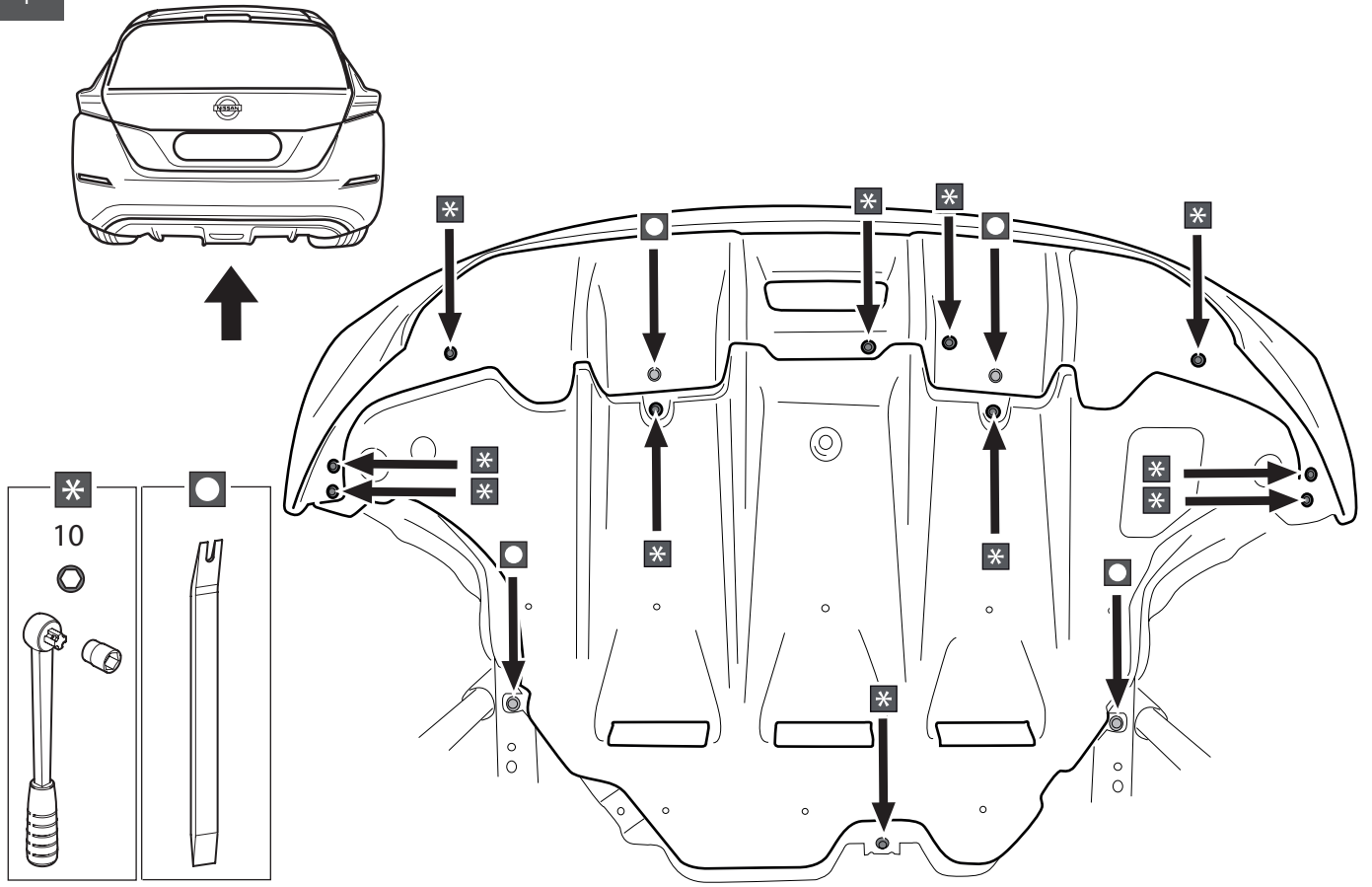

2

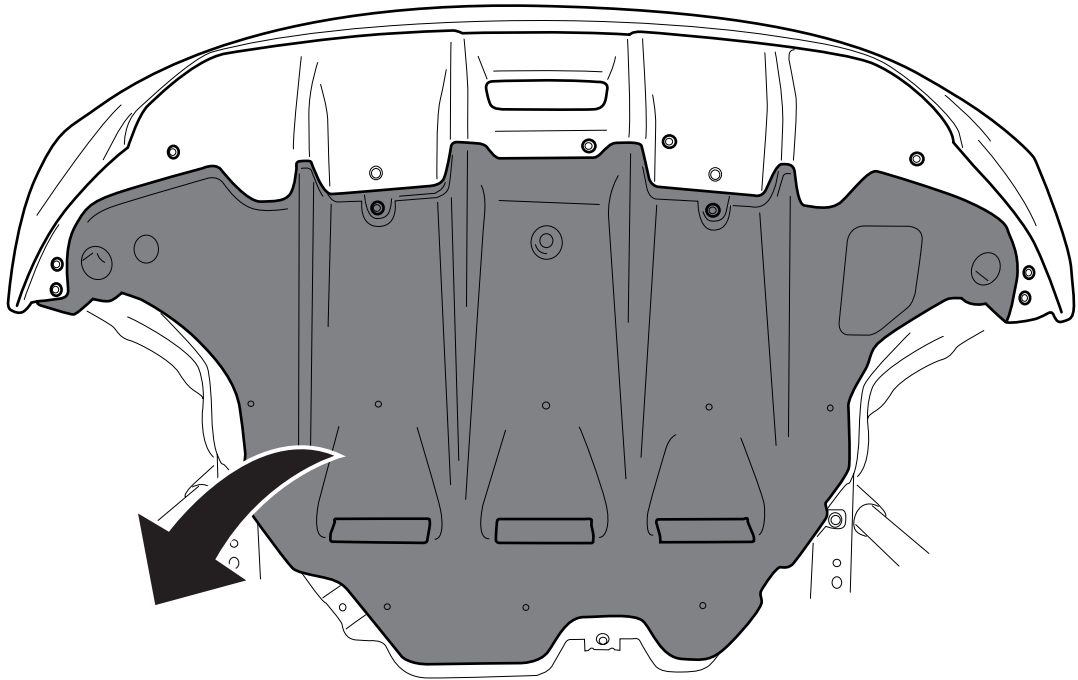

3

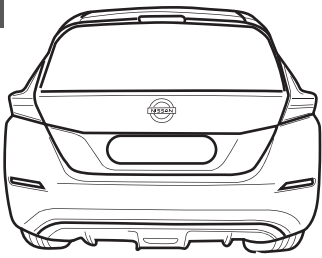

MODEL '10-'14

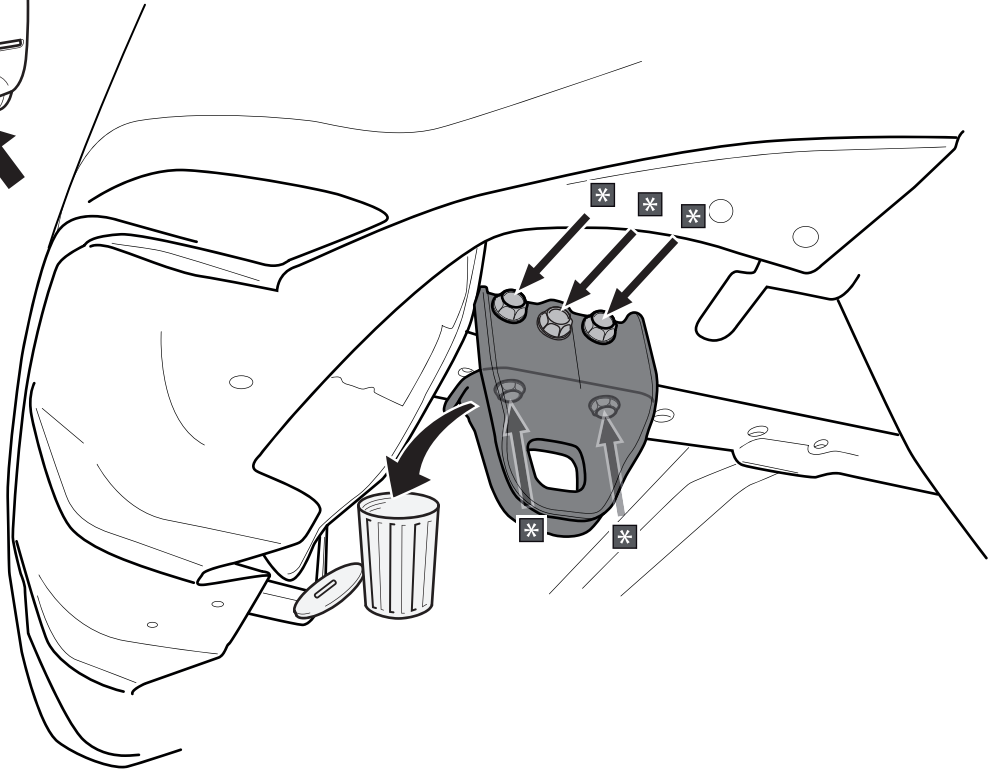
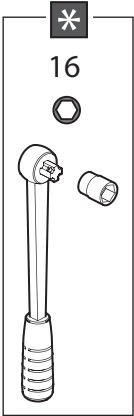

4



MODEL '14-

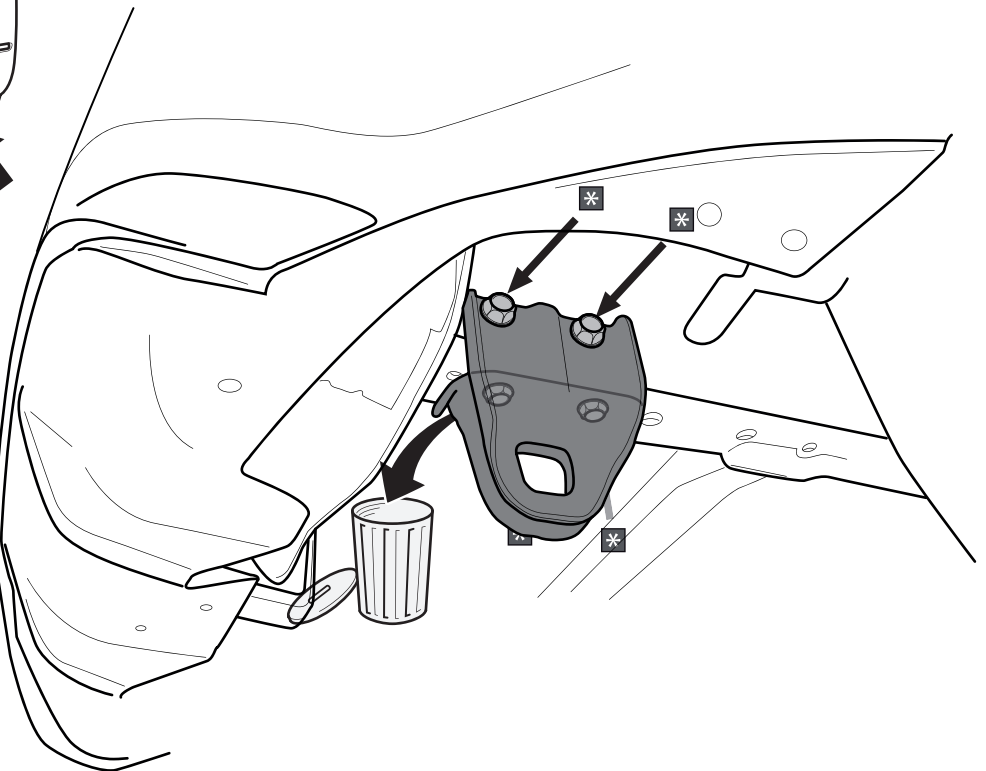
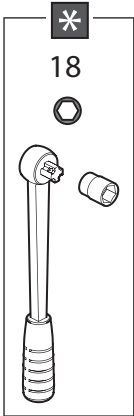



MODEL '10-'14

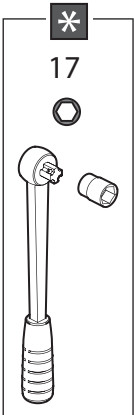
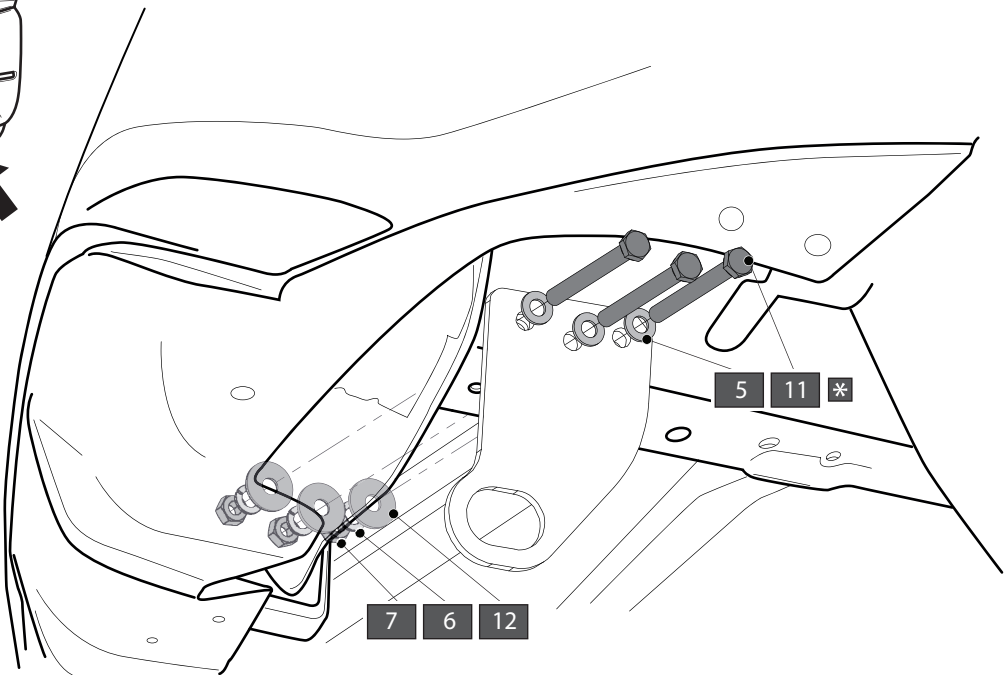
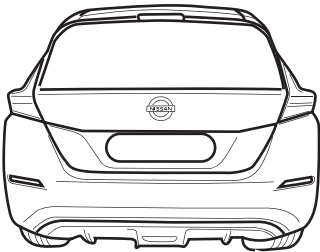

79,0 Nm

7

MODEL '14-

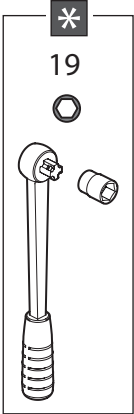
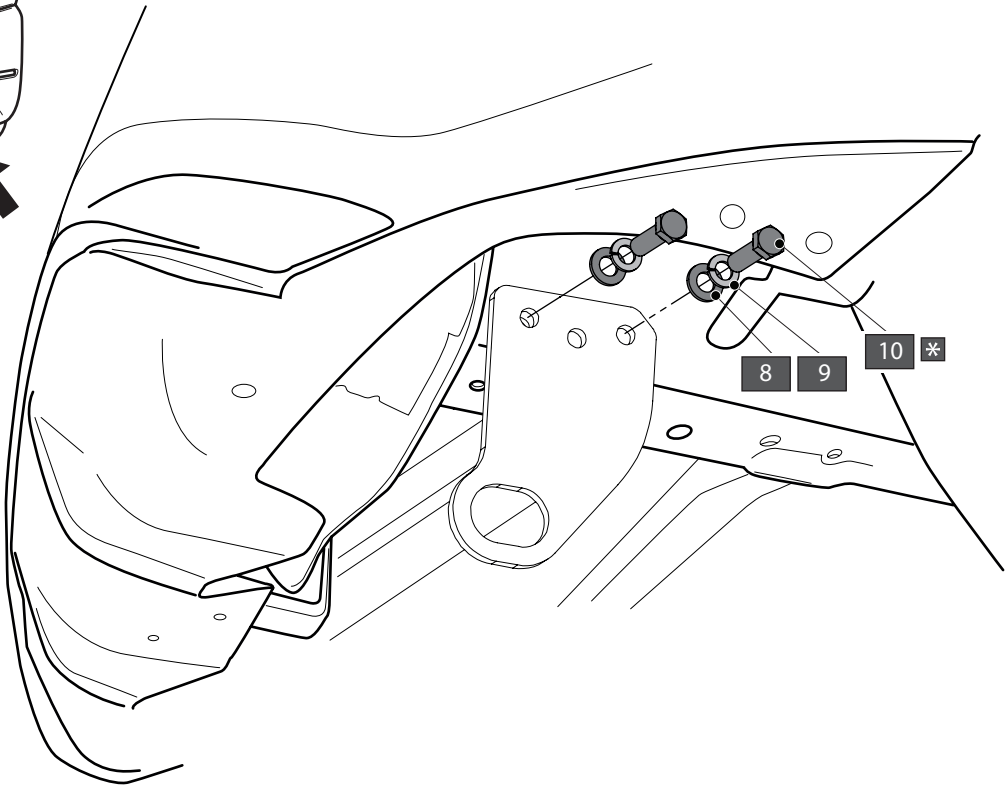
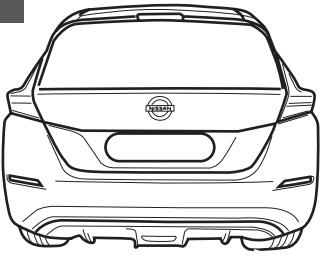

8

- ⚠ CONSTRUCTIE UITLIJNEN ⚠
- ⚠ ALIGNER LA CONSTRUCTION ⚠
- ⚠ ALIGN CONSTRUCTION ⚠
- ⚠ KONSTRUKTION AUSRICHTEN ⚠

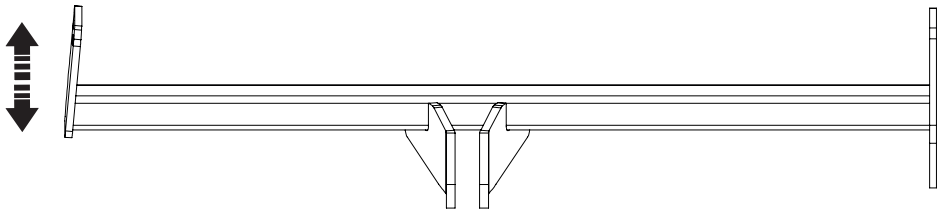
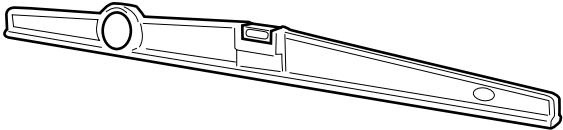

9

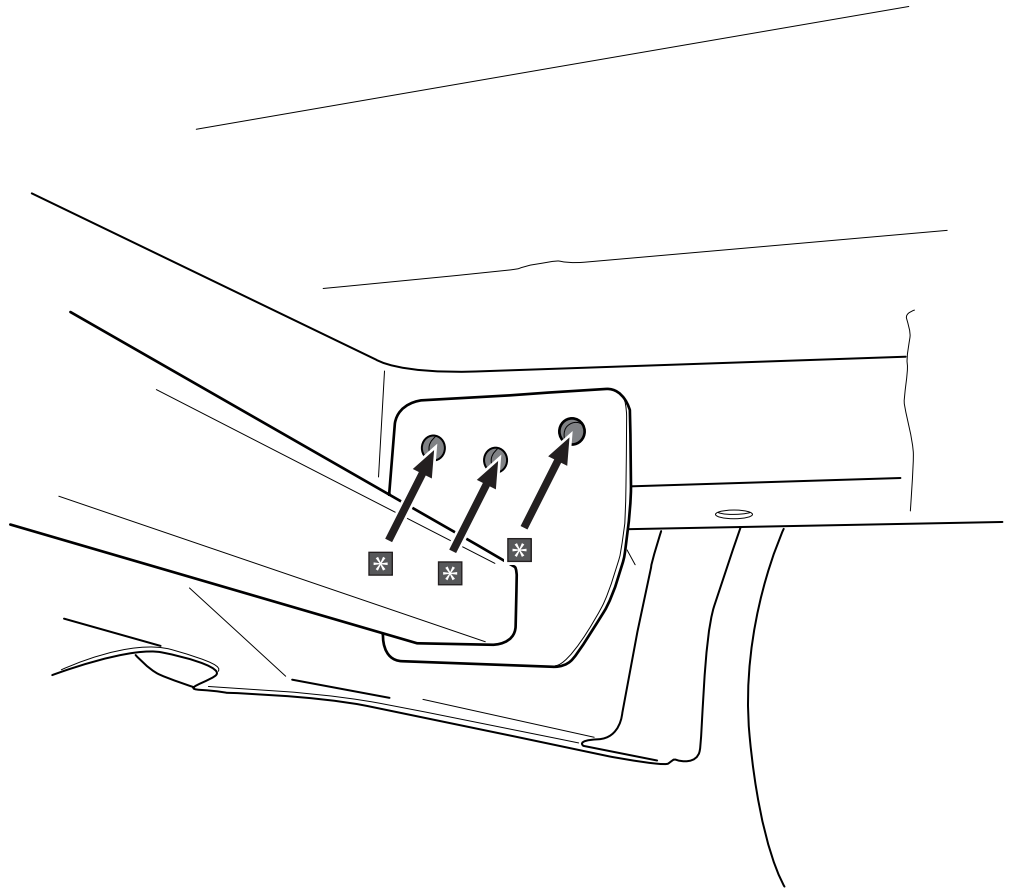
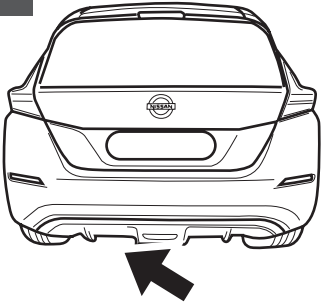

*

Ø 10,5

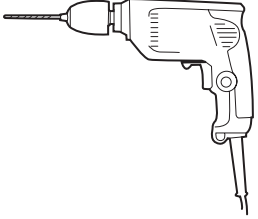

10

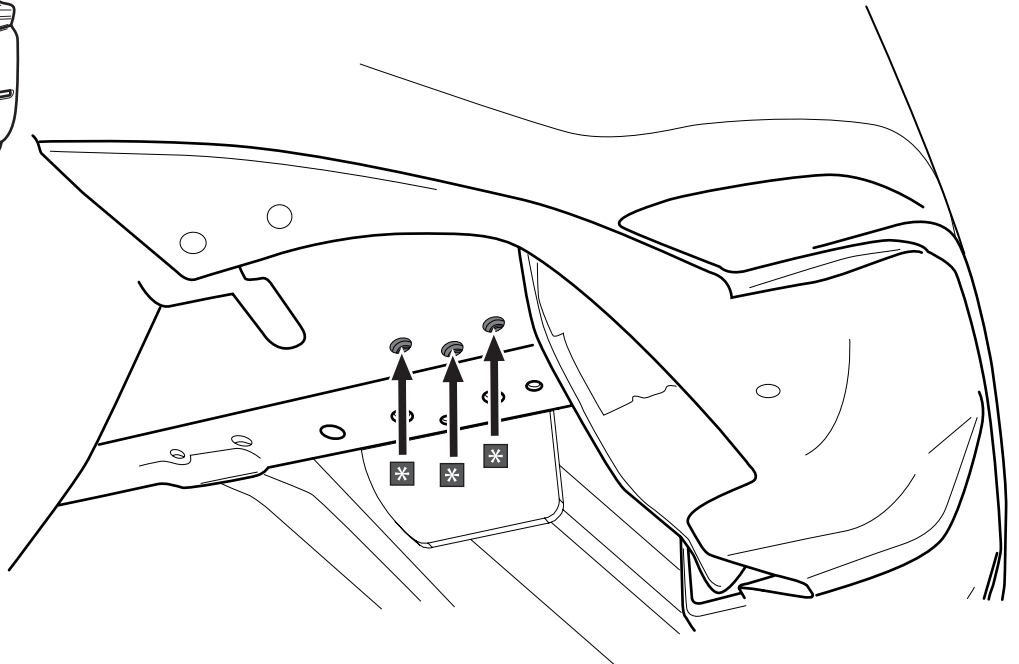
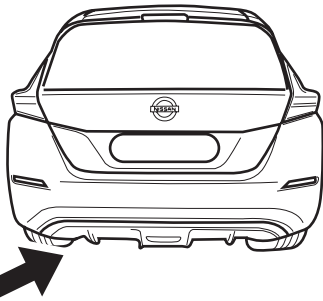





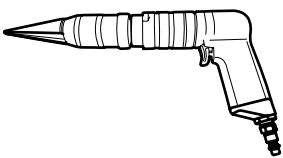

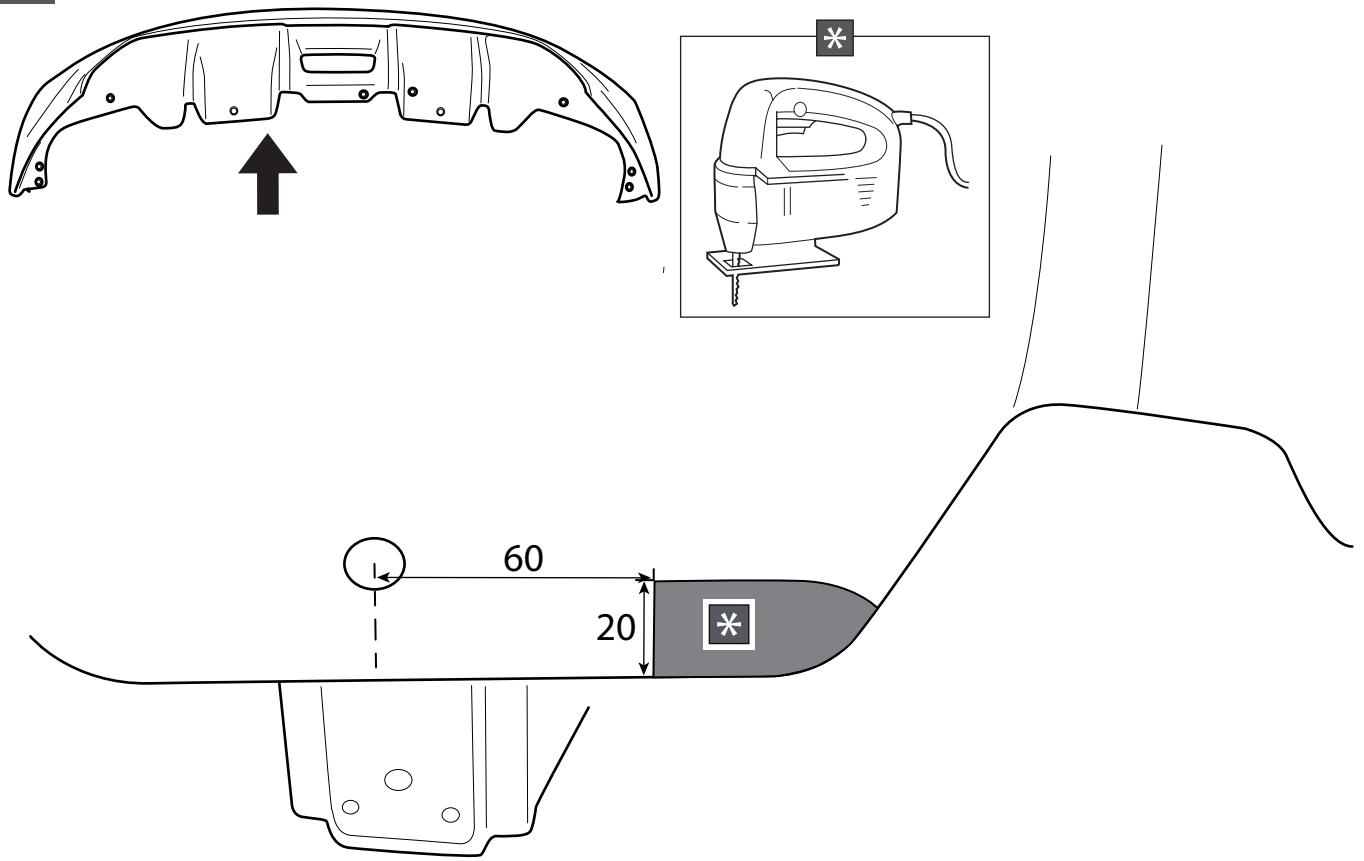
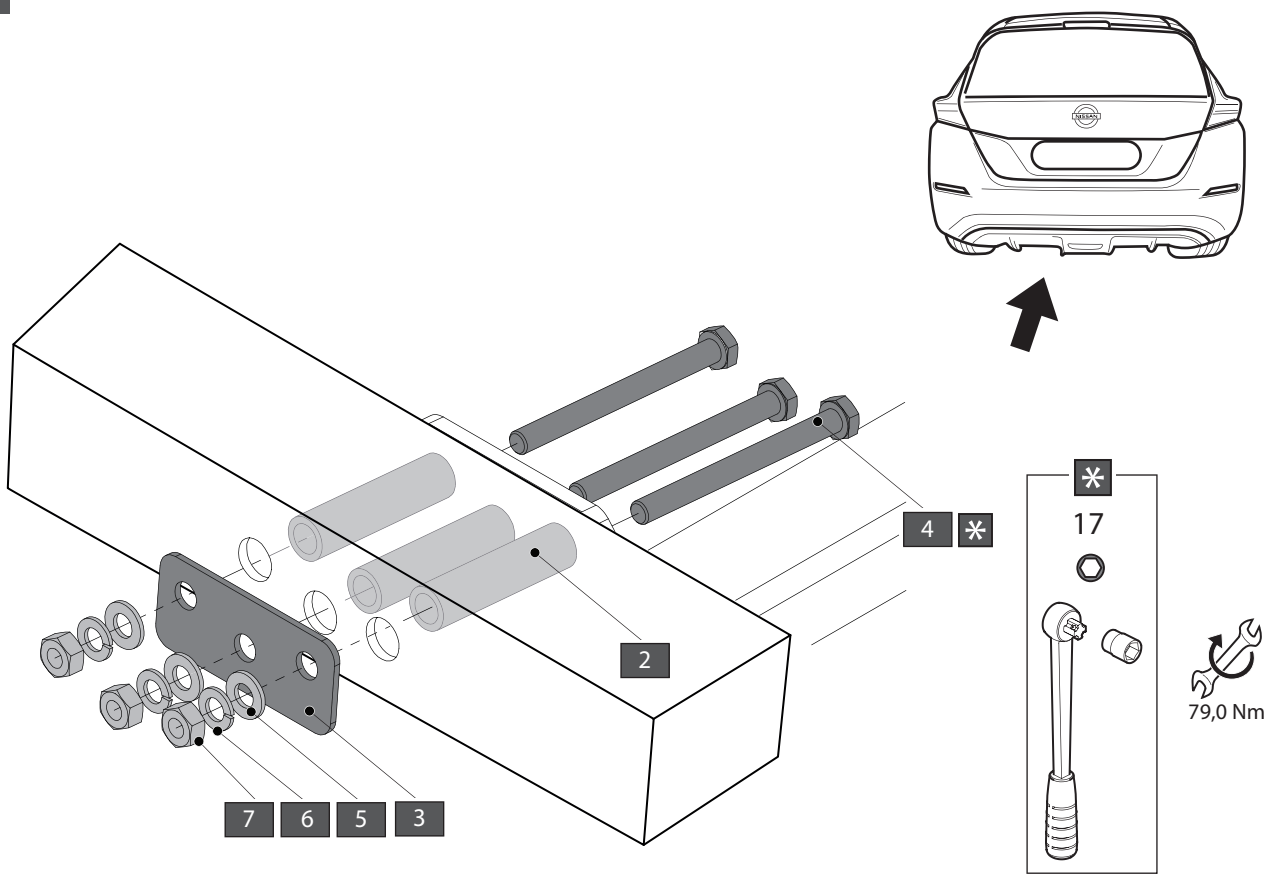
*

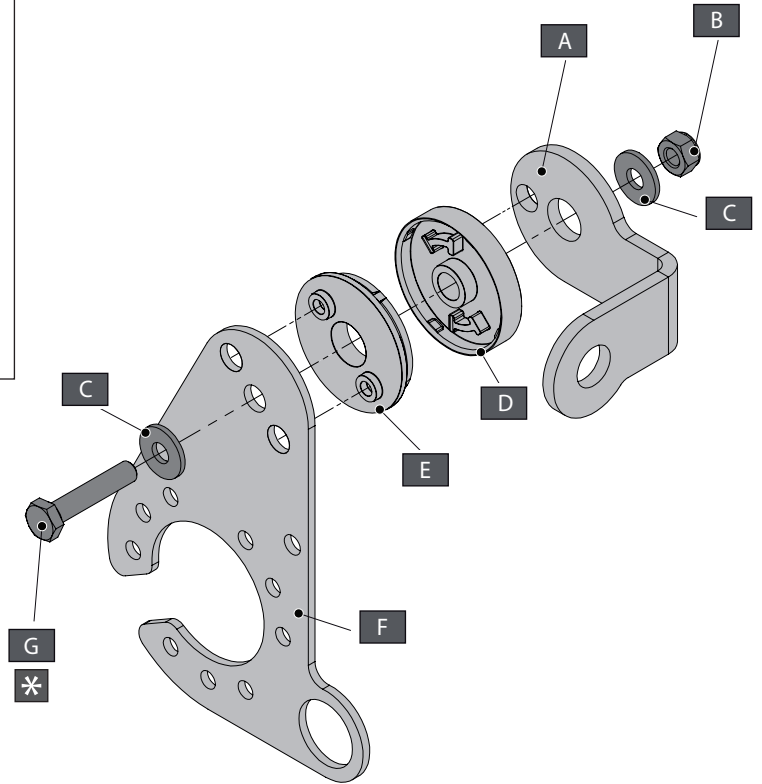
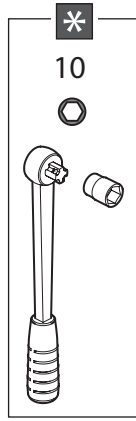
Ø 20

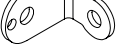



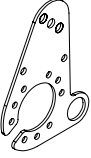

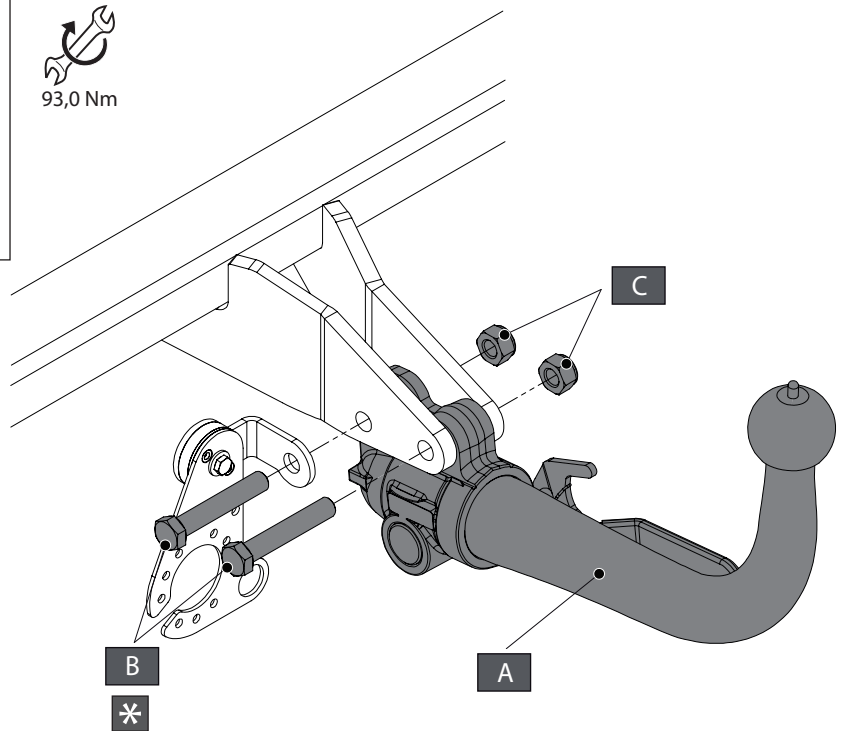
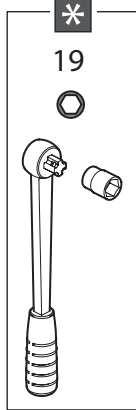

- A  X1 GDW REF. 908.095
- B  X1 DIN985-M6
- C  X2 6,2 X 15,4 X 1,6 (NYLON)
- D  X1 GDW REF. 718.16.002
- E  X1 GDW REF. 718.16.003
- F  X1 GDW REF. 908.094
- G  X1 DIN933-M6 X 30

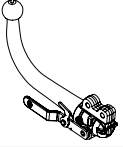
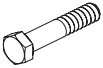

- A  X1 930.XL035T
- B  X2 DIN931-M12 X 70
- C  X2 DIN985-M12

15

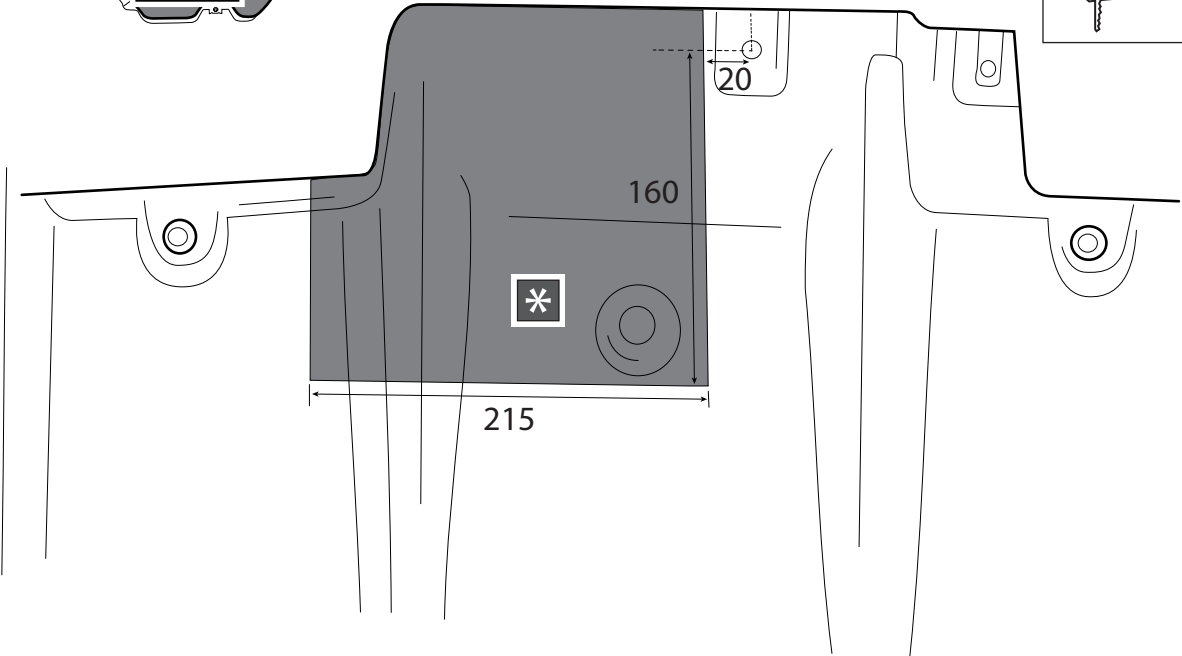
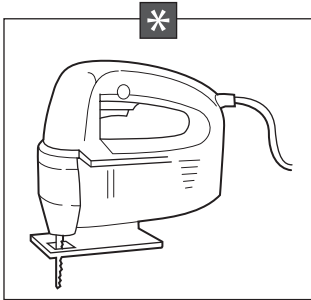
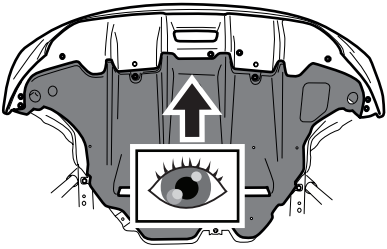

16

